

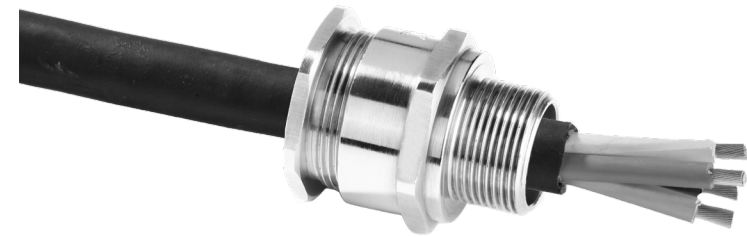

# INSTALLATION INSTRUCTIONS FOR A2F CABLE GLAND

CABLE GLAND FOR USE WITH UNARMoured AND BRAIDED CABLES IN EXPLOSIVE ATMOSPHERES

## INCORPORATING EU DECLARATION OF CONFORMITY TO DIRECTIVE 2014/34/EU AND UK STATUTORY REQUIREMENTS SI 2016 No. 1107 (AS AMENDED)



Cable Gland Size	Available Entry Threads (Alternate Metric Thread Lengths Available)					Overall Cable Diameter		Across Flats	Across Corners	Protrusion Length	Combined Ordering Reference (*Brass Metric)			Shroud	Cable Gland Weight (kg)
	Standard			Option		Min	Max	Max	Max		Size	Type	Ordering Suffix		
	Metric	Thread Length (Metric)	NPT	Thread Length (NPT)	NPT										
165*	M16	15.0	-	-	-	2.0	7.4	24.0	26.4	29.9	16S	A2F	1RA	PVC04	0.060
16	M16	15.0	-	-	-	3.2	8.7	24.0	26.4	29.9	16	A2F	1RA	PVC04	0.060
20S/16S*	M20	15.0	1/2"	19.9	3/4"	2.0	7.4	24.0	26.4	26.0	20S16S	A2F	1RA	PVC04	0.070
20S/16	M20	15.0	1/2"	19.9	3/4"	3.2	8.7	24.0	26.4	26.0	20S16	A2F	1RA	PVC04	0.070
20S	M20	15.0	1/2"	19.9	3/4"	6.1	11.7	24.0	26.4	26.0	20S16	A2F	1RA	PVC04	0.060
20	M20	15.0	1/2"	19.9	3/4"	6.5	14.0	27.0	29.7	27.7	20	A2F	1RA	PVC05	0.070
25	M25	15.0	3/4"	20.2	1"	11.1	20.0	36.0	39.6	35.5	25	A2F	1RA	PVC09	0.130
32	M32	15.0	1"	25.0	1 1/4"	17.0	26.3	41.0	45.1	35.1	32	A2F	1RA	PVC10	0.150
40	M40	15.0	1 1/4"	25.6	1 1/2"	23.5	32.2	50.0	55.0	35.0	40	A2F	1RA	PVC13	0.200
50S	M50	15.0	1 1/2"	26.1	2"	31.0	38.2	55.0	60.5	33.0	50S	A2F	1RA	PVC15	0.260
50	M50	15.0	2"	26.9	2 1/2"	35.6	44.0	60.0	66.0	37.3	50	A2F	1RA	PVC18	0.270
63S	M63	15.0	2"	26.9	2 1/2"	41.5	49.9	70.5	77.6	33.5	63S	A2F	1RA	PVC21	0.430
63	M63	15.0	2 1/2"	39.9	3"	47.2	55.9	75.0	82.5	36.2	63	A2F	1RA	PVC23	0.400
75S	M75	15.0	2 1/2"	39.9	3"	54.0	61.9	84.0	92.4	34.1	75S	A2F	1RA	PVC24	0.520
75	M75	15.0	3"	41.5	3 1/2"	61.1	67.9	84.0	92.4	40.9	75	A2F	1RA	PVC24	0.500
90	M90	24.0	3 1/2"	42.8	4"	66.6	79.9	108.0	118.8	60.3	90	A2F	1RA	PVC31	1.600
100	M100	24.0	4"	44.0	4"	76.0	91.0	123.0	135.3	57.2	100	A2F	1RA	LSF33	1.780
115	M115	24.0	4"	44.0	5"	86.0	97.9	133.4	146.7	67.3	115	A2F	1RA	LSF34	2.670
130	M130	24.0	5"	46.8	-	97.0	114.9	152.4	167.6	74.7	130	A2F	1RA	LSF35	3.800

*Dimensions are displayed in millimetres unless otherwise stated*

Note: Standard Seal (Black) Temperature Range = -60°C to +130°C, High Temperature Seal (Brown) Temperature Range = -60°C to +180°C for High Temperature Seal add 'HT' to ordering reference after Gland Type e.g. 20SA2FHT1RA. \*Only available with standard seal material and ATEX/IECEx/UKEX certification.

FI413		
Certificate	Revision	Date
UKEX	1	01/24
IFS	24	04/24
ATEX / IECEx	4	01/24
CSA	2	01/17



Glasshouse Street • St. Peters • Newcastle upon Tyne • NE6 1BS  
 Tel: +44 191 265 7411 • Fax: +44 1670 715 646  
 E-Mail: customerservices@cmp-products.com • Web: www.cmp-products.com

### TECHNICAL DATA

**CABLE GLAND TYPE** : A2F  
**INGRESS PROTECTION** : IP66, IP67, IP68, NEMA 4X  
**PROCESS CONTROL SYSTEM** : ISO 9001  
 ISO/IEC 80079-34:2011

### EXPLOSIVE ATMOSPHERES CLASSIFICATION

**ATEX CERTIFICATION No** : CML 18ATEX1321X, CML 18ATEX4313X  
**ATEX CERTIFICATION CODE** : II 2G Ex db IIC Gb, II 2G Ex eb IIC Gb, II 1D Ex ta IIC Da IP66, 67, 68  
 II 3G Ex nR IIC Gc IP66, 67, 68  
**UKEX CERTIFICATION No** : CML 21UKEX1245X, CML 21UKEX4246X  
**UKEX CERTIFICATION CODE** : II 2G Ex db IIC Gb, II 2G Ex eb IIC Gb, II 1D Ex ta IIC Da IP66, 67, 68  
 II 3G Ex nR IIC Gc IP66, 67, 68

**IECEx CERTIFICATION No** : IECEx 18.0179X  
**IECEx CERTIFICATION CODE** : Ex db IIC Gb, Ex eb IIC Gb, Ex ta IIC Da, Ex nR IIC Gc IP66, IP67, IP68  
**CSA CERTIFICATION No** : 1211841  
**CSA CERTIFICATION CODE** : Ex d IIC, Ex e II, Ex nR II, Enclosure Type 4X

### INSTALLATION INSTRUCTIONS

- Installation should only be performed by a competent person using the correct tools. Spanners should be used for tightening. Read all instructions before beginning installation.
- The interface between a cable entry device and its associated enclosure / cable entry will require additional sealing to achieve ingress protection (IP) ratings higher than IP54. The minimum protection level is IP54 for explosive gas atmospheres and IP6X for explosive dust atmospheres. Parallel threads (and tapered threads when using a non-threaded entry) require a CMP sealing washer or integral O-ring face seal (where available) to maintain IP66, 67 and 68 (when applicable). It is the installer's responsibility to ensure the IP rating is maintained at the interface.  
 Note: When fitted to a threaded entry, all tapered threads will automatically provide an ingress protection rating of IP66.  
 A CMP earth tag should be used when it is necessary to provide an earth bond connection. CMP earth tags have been independently tested to comply with Category B rating specified in IEC 62444 (there are no ratings stated in IEC 60079-0). Ratings are shown in the associated table. CMP earth tags slip over the cable gland or accessory entry thread from inside/outside the enclosure and must be secured with a locknut (if fitted internally).
- Metric entry threads comply with ISO 965-1 and ISO 965-3 with a 6g tolerance as required by IEC 60079-1:2014. The CMP standard metric thread pitch is 1.5mm for threads up to M75, and 2.0mm from M90 and above. Special thread pitches between 0.7 – 2.0mm are available on all products on request. See certificate for details of other thread types. NPT threads are in accordance with ASME B1.20.1-2013 gauging to CI 3.2 for external threads. For details of other thread types refer to IECEx certificate.
- Enclosures must be strong enough to support the cable and cable gland assembly. The enclosure surface finish must be smooth and flat to facilitate sealing with an O-ring or Entry Thread Sealing Washer for the required IP rating.
- Enclosure walls must be sufficiently strong enough to support the cable and cable gland assembly. Enclosure entries shall be perpendicular. Any draft angles from the casting/moulding process should have a perpendicular flat spot machined to facilitate sealing with an O-ring or Entry Thread Sealing Washer.
- CMP Products recommends that when using the cable gland with a through-hole, the hole must be circular, free of burrs and the diameter no larger than 0.7mm above the thread major diameter. A suitable CMP Products locknut shall be used to secure the product. See CMP Products catalogue for locknut options.
- Cable glands do not have any serviceable parts and are therefore not intended to be repaired.

### SPECIFIC CONDITIONS OF USE

- All cable gland types and sizes are only suitable for fixed installations. Cables must be effectively clamped to prevent pulling or twisting.
- The entry item component may be supplied with an alternative nearest equivalent recognised thread type and size to the metric thread, whilst maintaining a tolerance of fit, equal to or better than, a medium fit to ISO 965-1 & ISO 965-3. Intended for use within existing installations only, that incorporate female thread types that are no longer permitted by the current edition of EN/IEC 60079-1, but comply with the requirements of EN 50018:2000 & IEC 60079-1:2001
- When the cable glands are supplied with an entry thread that is one size up from the nominal gland size, designated with the letter 'B' after the gland size, e.g. 32B\*\*\*\*, they shall not be used with any adaptor device.
- The cable glands shall only be used where the temperature, at the point of entry, is in the following ranges:  
 a. EPDM (Black): -60°C +130°C  
 For Ex d applications, cable gland types CA2F, CA2F-RC, CA2F-FC, CA2F-HC and CA2F-FF are to be installed in associated Ex d equipment having a minimum wall thickness as follows:  
 a. 10.5mm minimum for cable gland having entry thread sizes M16 x 1.5 to M75 x 1.5  
 b. 12.5mm minimum for cable gland having entry thread sizes M90 x 2.0 to M115 x 2.0  
 Designed for appropriate Steel Tape Armour (STA), Steel Wire Armour (SWA), and appropriate braided cable. These cables must be extruded sealing (solid polymeric) completely surrounding the "core" (insulation and conductor), allowing for no holes or ventilation through the inner jacket or along the cores.
- IEC Canadian Standards may have either tapered or non-tapered threads which comply with ISO Standards.
- According to CEC C22.1 -98, Section 18-106 Part 3, Tapered Threads shall have 5 fully engaged threads, and where non-tapered threads are used in Groups IIC there must be 8 fully engaged threads.

### ACCESSORIES

The following accessories are available from CMP Products, as optional extras, to assist with fixing, sealing and earthing:  
 Locknut, Earth Tag, Serrated Washer, Entry Thread (I.P.) Sealing Washer, Shroud

CMP Earth Tag Size	Short Circuit Ratings Symmetrical Fault Current (kA) for 1 second
20	3.06
25	4.06
32	5.40
40	7.20
50	10.40
63	10.40
75	10.40

CMP Products Limited on its sole responsibility declares that the equipment referred to herein conforms to the requirements of the ATEX Directive 2014/34/EU and UK statutory requirements SI 2016 No. 1107 (as amended). This is shown in the following harmonised/designated standards; and/or the latest technical knowledge.

EN IEC 60079-0:2018, EN 60079-1:2014, EN IEC 60079-7:2015 + A1:2018, EN IEC 60079-15:2019, IEC 60079-31:2022

Malcolm Webber - Product Engineering Manager - (Authorised Person)  
 CMP Products Limited, Cramlington, NE23 1WH, UK

EU Economic Operator: CMP Products Germany GmbH. Address: Lukasstraße 25a, 52070 Aachen  
 17th March 2020

**CE 2776** Notified Body: CML B.V., Koopvaardijweg 32, 4906CV Oosterhout, The Netherlands

**UK CA 2503** Approved Body: Eurofins E&E CML Limited, Newport Business Park, New Port Road, Ellesmere Port, CH65 4LZ

# INSTALLATION INSTRUCTIONS FOR CMP CABLE GLAND TYPES A2F

CABLE GLAND COMPONENTS - It is not necessary to dismantle the cable gland any further than illustrated below

- 1. Entry Item
- 2. Seal
- 3. Seal Nut

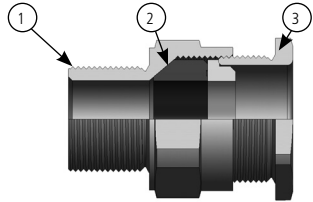

## PLEASE READ ALL INSTRUCTIONS CAREFULLY BEFORE BEGINNING THE INSTALLATION

1. It is not necessary to dismantle the gland any further than illustrated below.

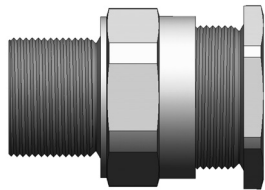

2. Fit the gland into the equipment and fully tighten the entry item (1).

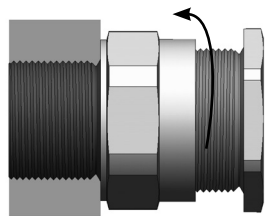

3. Determine the conductor length required to suit the installation and prepare the cable accordingly, removing part of the outer sheath where required to reveal the insulated conductors.

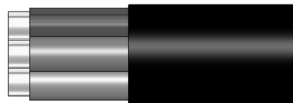

4. Slacken the seal nut (3) to relax the seal (2).

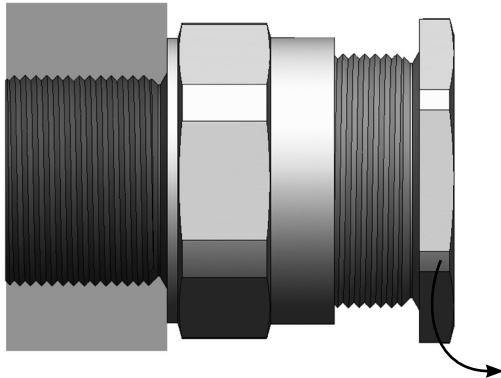

5. Pass the cable through the gland to the desired position, then tighten the seal nut using a spanner until resistance is felt (when the seal contacts the cable). Tighten with a spanner one further turn.

